



Introduction

Thank you for purchasing VLR Vortex engines. This manual contains information to help you to get the best results from your new engine. Furthermore, it will explain you how to operate your Vortex engine safely and in a proper manner. All the information in this manual is based on the latest experience and product information available at the time of writing. Vortex reserves the right to make any kind of changes to this manual at any time without notice and/or incurring in any obligation.

OTK KART GROUP s.r.l.
Via dei Soprini 16
25080 Prevalle (Brescia) IT

VORTEX Factory
Via E. Fermi 5
27040 Campospinoso (Pavia)IT

support@vortex-engines.com

TABLE OF CONTENT

Chapter	Information	Page
1	GENERAL INFORMATION	
	Symbols	3
	Safety information	3
	Technical specifications	4
	Special technical specifications for homologated engine	5
	Packaging	5
2	ENGINE ASSEMBLY	6
	Engine bracket	7
	Coil	7
	Spark plug	9
	Battery and electronic harness	10
	Carburetor	13
3	ENGINE RUNNING IN	15
4	MAINTENANCE	16
	Maintenance schedule guide and adjustments	16
	Torque chart	16
	General tolerances	16
	Maintenance detailed chart	17
	Carburetor cleaning	17
	Spark plug cleaning and replacement	19
	Exhaust cleaning	19
	Cylinder head cleaning	20
	Cylinder check and maintenance	21
	Piston check and maintenance	22
	Cleaning and/or replacing clutch	23
	Replacing starter gear	24

GENERAL INFORMATION

SYMBOLS

Pay attention to the symbols of this manual. They alert you of dangerous situations for you or for your engine.



Personal Injury



Mechanical Danger



Caution



In order to perform a job, special tools are requested.

SAFETY INFORMATION

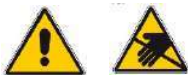

- Do not start the engine indoors garages, trailers etc. Start the engine in a well-ventilated area only. Exhaust emission are hazardous to your health.
- Always wear gloves and proper clothing when working on your engine.
- Use caution when handling fuel, as fuel is very flammable and explosive. When working with fuel, do not smoke or use it near fire or flames. Avoid any skin contact and inhaling fuel vapors.
- Never touch moving parts when the engine is running.
- During operation, both engine and muffler, become very hot. Do not touch them and do not place anything on them after operation.
- Do not touch the spark plug or cable. It may provoke electrical shocks.
- Understand the operation of all controls and learn how to stop the engine quickly in case of emergency.
- Do not use the engine without clutch cover and chain protection.

VLR Engine Manual

TECHNICAL SPECIFICATIONS

Engine		Max	Min
Displacement	98.53 cc	100 cc	n.a.
Bore	48.20 mm	+0.2 mm	-0.2 mm
Stroke	54.00 mm	+0.2 mm	-0.2 mm
Squish	1.10 mm	n.a.	1.00mm
Combustion Chamber			9.2 cc
Engine Type	Air Cooled		
Engine Weight	14.5 kg		

Intake System		
Inlet	Reed Valve	
Carburetor	Tillotson	HW-38A
Air Box type	Aero type C 0226 GLA22	

Ignition System	Type	Space
Selettra	Analogic	
Recommended time setting		3mm
Sparkplug	NGK B10 EG NGK BR10 EG NGK R6252 K-105 NGK 6254-105	

General		Type
Mix	4%	
Gear Oil	280 g W10/40	JASO MA-2 o API SL
Engine Weight	14.5 kg	

-All sizes and measurements in this manual are expressed in metrics.

-Always use original Vortex parts and proper tools when working on your engine. Proper fuel mix is necessary for optimum engine life and performance.

SPECIAL TECHNICAL SPECIFICATIONS FOR HOMOLOGATED ENGINES

Vortex Rok VLR is produced in two versions, VLR and VLR-J with manifold restrictor as showed in the engine VLR homologation form. For specific rules and/or sizes refer to your country



homologation file

PACKAGING

Your engine will be packed in a sealed box with the Vortex logo printed on and a sticker with model and serial number attached. In a complementary box all the accessories as carburetor, muffler and more will be provided.

The boxes need to have the original vortex logo.



The engine box an official OTK KART USA sticker.



And on the engine starter motor there needs to be an official OTK KART USA sticker too.



ENGINE ASSAMBLY

In order to assemble the engine, you will need the following tools:



Type	Size
Compressed air	
Allen T-wrench	3
Allen T-wrench	4
Allen T-wrench	5
Allen T-wrench	6
Allen T-wrench	8
Fixed wrench	5 mm
Fixed wrench	7 mm
Fixed wrench	8 mm
Fixed wrench	10 mm
Fixed wrench	13 mm
Fixed wrench	17
Fixed wrench	22
Crosshead screwdriver	
Flathead screwdriver	
Spark plug wrench	
Plier	
Torque wrench	
Heater	
Metal brush	

Compressed air



Unpack the engine and remove any packaging material on it. Clean the engine with compressed air and after take of the protecting PVC cups on the inlet, exhaust and spark plug.



ENGINE BRACKET

6mm Allen T-Wrench

 Lay the engine on its side and attach the engine mount to the engine base with four 8mm Allen screws. Engine mount and screws come with the engine.

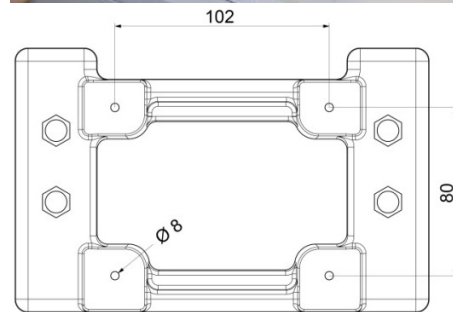

COIL

10mm fixed wrench

 Assemble coil support and coil as per instructions. All needed parts come with the engine.

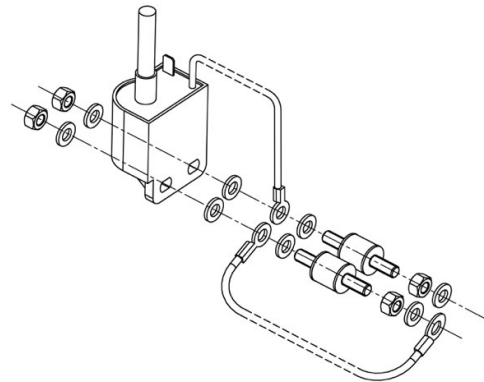

Assemble the two silent blocks on the coils support plate in the engine by inserting between the plate and the silent block the ground cable.



Secure the two silent block by locking the M5 nuts.



Insert coil in the two silent blocks. And lock everything in place with two M5 nuts

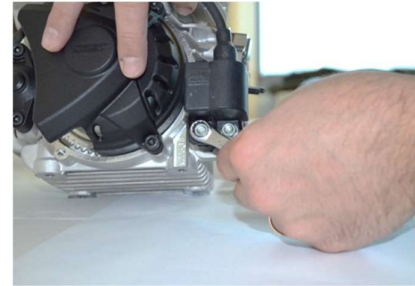

Insert the first part of the ignition cable from the coil in to the silent block. Make sure it is safe and secure



And the end of the ignition cable into the starter engine cable (see picture)



Be careful when assembling the ignition cable, the end must be in contact with the coil metal support. Wrong assembling will result in coil failure and/or the engine not starting.

SPARK PLUG

Unbox the spark plug, the ignition distance must be 0.8 mm like in the draw

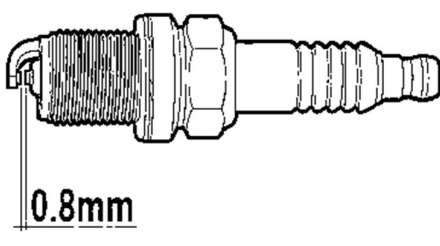

Spark Plug Wrench Plier

Remove the PVC cap with the plier from the cylinder head.

Manually tighten the spark plug into the cylinder head.

Lock and unlock with the spark plug wrench 2/3 times to allow the gasket to seat properly. Now you can tighten the spark plug properly.

Insert the cable coil in the spark plug cap and tighten it. For safety, we recommend you to secure the cable coil to the spark plug cap with a plastic strap. Place the spark plug cap on the spark plug and press the cap fully.



BATTERY AND ELECTRONICS HARNESS



5 mm Allen T-Wrench

Mount the battery holder on the chassis at the side of the seat using the plastic (upper) and iron (lower) jumpers supplied.

A mounting spacer between the jumpers and battery holder may be necessary to overcome the brake hose.



4 mm Allen T-Wrench 10 mm Fixed Wrench

Remove the relay from its housing in the wiring. Fix the housing of the relay to the battery holder using the 6x25 mm screw, the double cone washer, the two rubber spacers, the washer and the 6 mm nut.

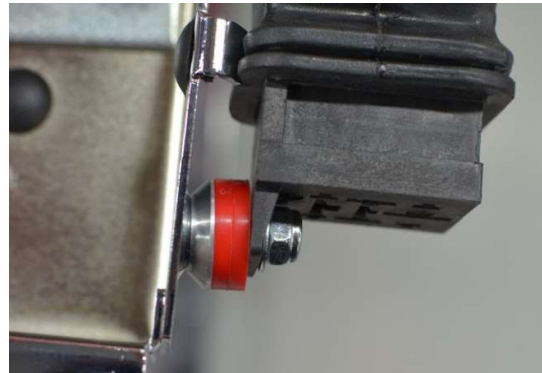

Manually place the relay into the wiring. No tools are needed to do this.





14 mm Fixed Wrench

Place the start button (green) and the stop button (red) in the two slots in the front of the battery holder. Secure them by tightening the nuts already placed on the wiring cable.



Place the battery inside the battery holder itself. Insert the wiring cables in the battery plugs. The red cable into the red plug and the black wire into the black plug. Secure the battery to its holder using the two rubber O-rings supplied.



Secure the relay with the specific spring provided. Make sure that the spring is in the correct position and press. If it is necessary, bend slightly the spring end with a caliper so as to ensure proper fastening.

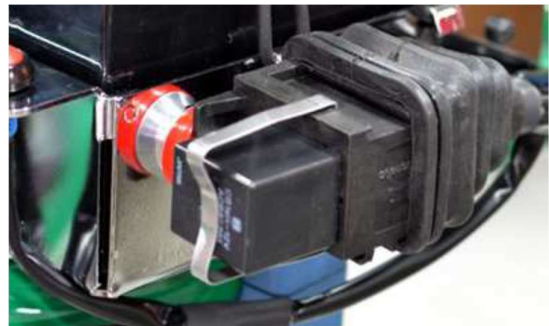

Pass the main cable to the side of the seat and secure it to the frame using the plastic straps. Make sure there are no loose cables, they could touch the asphalt and become damaged beyond repair.



Insert the plug that you find at the end of the cable from the battery with the other plug of the cable already placed on the engine.

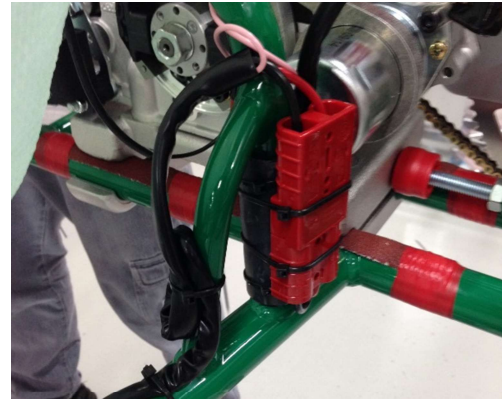

EXHAUST MANIFOLD

For the exhaust manifold there are two options, the standard VLR and VLR JUNIOR. Make sure when assembling the manifold is locked secure and safely in its place.

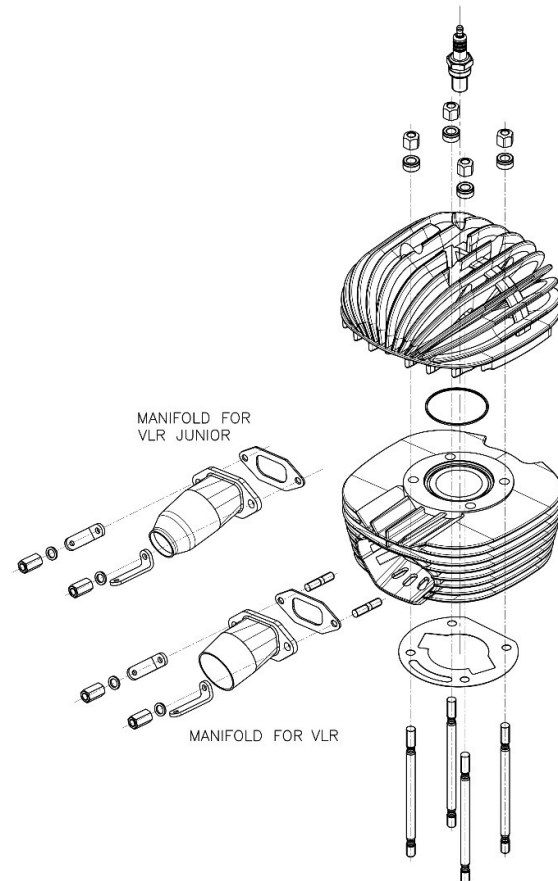

CARBURETOR



PLIER
5 mm fixed wrench

Remove the plastic cap from the intake manifold with the plier.



Take the carburetor out of the box.



Test the pressure of the carburetor with a pressure pump gauge and connect it to the fuel intake (see picture). The carburetor must be wet, so make sure it has run some fuel before performing this test.



The carburetor valve needs to open at 7.5-8 bar and close between 5.5-6 bar.

After every race, remove the fuel from the carburetor with the pump. For a better and longer maintenance.



Putt the carburetor over the tow pins on to the intake manifold, like in the picture.

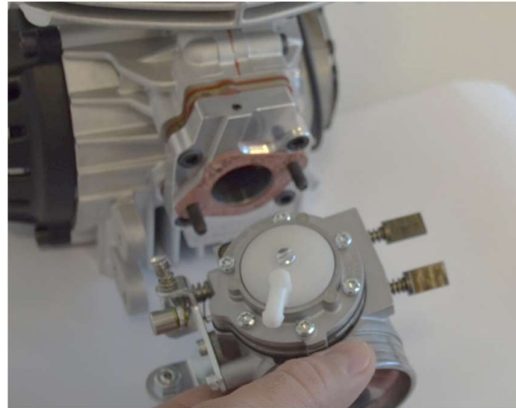

Bold the carburetor on to the two pins with the bolts provided in the plastic bag. While locking the carburetor it needs to be lined up properly with the manifold. Make sure the carburetor is locked properly and secure.

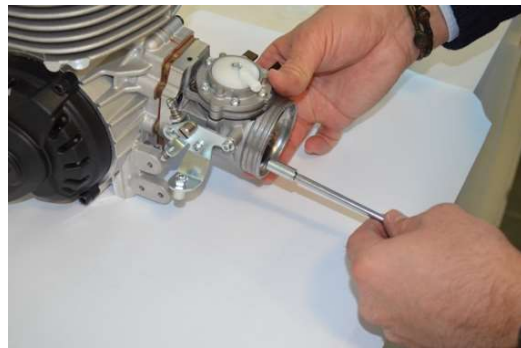

Secure the throttle cable on the slide. Feed the throttle cable inside the register and the making sure to leave the cable inside.
Feed the throttle cable through carburetor slide spring. Pull the slide from the carburetor. Place the ball at the end of the throttle cable through the hole in the center of the slide. Lock the throttle cable inside the slide by moving the cable to the side to the center.
Place the slide and the spring in the carburetor.

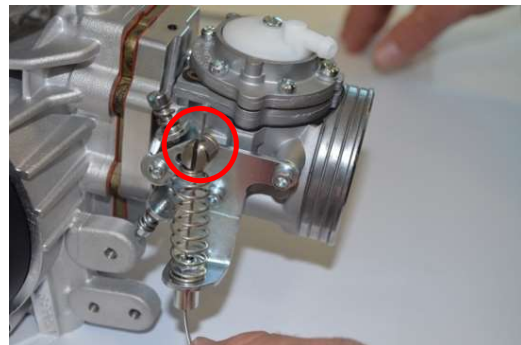

Very carefully, by using the pliers, turn the two carburetor vents so that they are facing up.

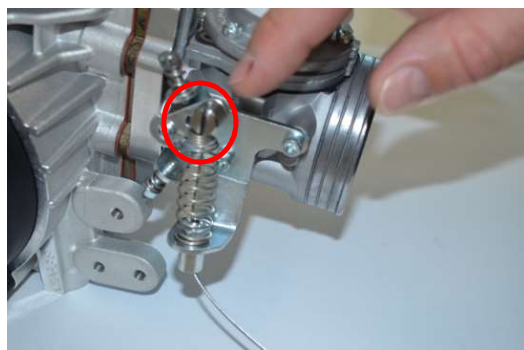

ENGINE RUNNING IN

ENGINE BREAK IN

Only a proper break-in will insure the best performance out of your engine in the future and guarantee its long and trouble-free life. Break-in is required when an engine is new or has undergone a major service of the engine's main parts (piston, cylinder, connecting rod, etc.).

Prepare fuel. Vortex engine works with commercial gasoline, leaded or unleaded, as well as racing fuel, with minimum 95 Octane. Mix Oil and fuel at 4% (i.e. 40cc of oil every 1.000cc of fuel). Use high-quality synthetic oil specifically made for kart engines. Vortex suggests Rok Lube, however other brands with the same composition might be suitable.

Shake the can thoroughly to mix the fuel and the oil properly. Then fill the gas tank in your kart.



A mistake in measurements could result in engine damage.



Do not accelerate fully but only partially.



Check that the cooling system warms up evenly; in case it warms unevenly proceed again with the bleeding of the cooling system.

Once the engine is warmed up and the cooling system works properly, proceed to the track. Run the engine by alternating RPM's a few seconds on and off the throttle at 3/4 maximum throttle.

Do not hold the throttle at a constant speed. Continue this way for 5/6 laps and return to pits. Check everything on the kart is tightening properly.

Be careful, both engine and muffler are hot.



Return to the track and slowly increase the RPM and duration of the acceleration phase for 10/15min more. Intermittently open the throttle fully and then release it.

After 10/15 minutes of brake-in, your engine is ready for competition.

During the break-in, nuts and bolts tend to loosen. Once the engine is cold, check the torque of the exhaust, head, etc.



MAINTENANCE

Good maintenance is essential for safe, economical and trouble-free operation. Here you will find a maintenance schedule for your engine. Routine inspection procedures are very simple by using basic tools. Some service tasks that are more difficult or needs special tools must be performed by Vortex technicians or qualified mechanics.



Timing schedule periods are only indicative. Extreme carburation set ups highly modify timing schedule periods.

Maintenance schedule guide an adjustments

Part	Frequency	Operation
Carburetor	Every day	Cleaning
Accelerator cable	Every race	Check
Spark plug	Every race	Check
piston pin	60 liters	Substitution
Piston pin roller cage	60 liters	Substitution
Connection rod	400 liters	Substitution
Crank shaft pin	200 liters	Substitution
Silver washer	200 liters	Substitution
Crank shaft roller cage	200 liters	Substitution
Crank shaft bearings	800 liters	Substitution

Torque chart

Part	Torque in Nm
Cylinder head nuts	1.6
Crankcase \varnothing 6 mm screws	1.0/1.1
Ignition rotor nut	1.8
Exhaust manifold nut	1.0/1.1
Clutch nut	4.5

General tolerances

Part	Type	Measure	Operation
Cylinder	Ovalization	0.02	Honing
Piston/cylinder	Clearance	0.09	

MAINTENANCE DETAIL CHART

In the following section, you will find a detailed most important maintenance jobs to be performed.

CARBURETOR CLEANING

Flat Screwdriver



1. Take the air box off the carburetor by unscrewing the clamp.
2. Disconnect the throttle cable from the carburetor.
3. Take the carburetor off the engines and check the carburetor pressure like explained in *carburetor assembly* page 13.
4. Make sure all the fuel is out of the carburetor.
5. If the pressure of the carburetor is good, do not change anything and continue racing with it.
6. If the pressure is not good, you must replace all the gaskets. It is highly suggested to replace the jets, needle and O-ring which are all available in repair kit one.
7. Make sure when reassembling it is in according with page 18 *carburetor assembly*.



Wrong assembly will cause malfunctioning of the carburetor.

For changing the carburetors gasket and jets there are two sets available.

- Repair kit 1, a complete repair set with all the gaskets, a needle, jets and O-ring.



- Set two with only gaskets

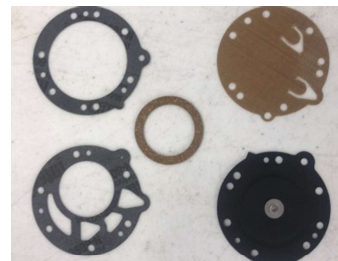

VLR Engine Manual

CARBURETOR ASSEMBLY



HW-33A EXPLODED VIEW

DATE	DRAWN BY	REVISION
26/10/2018	P.B	01

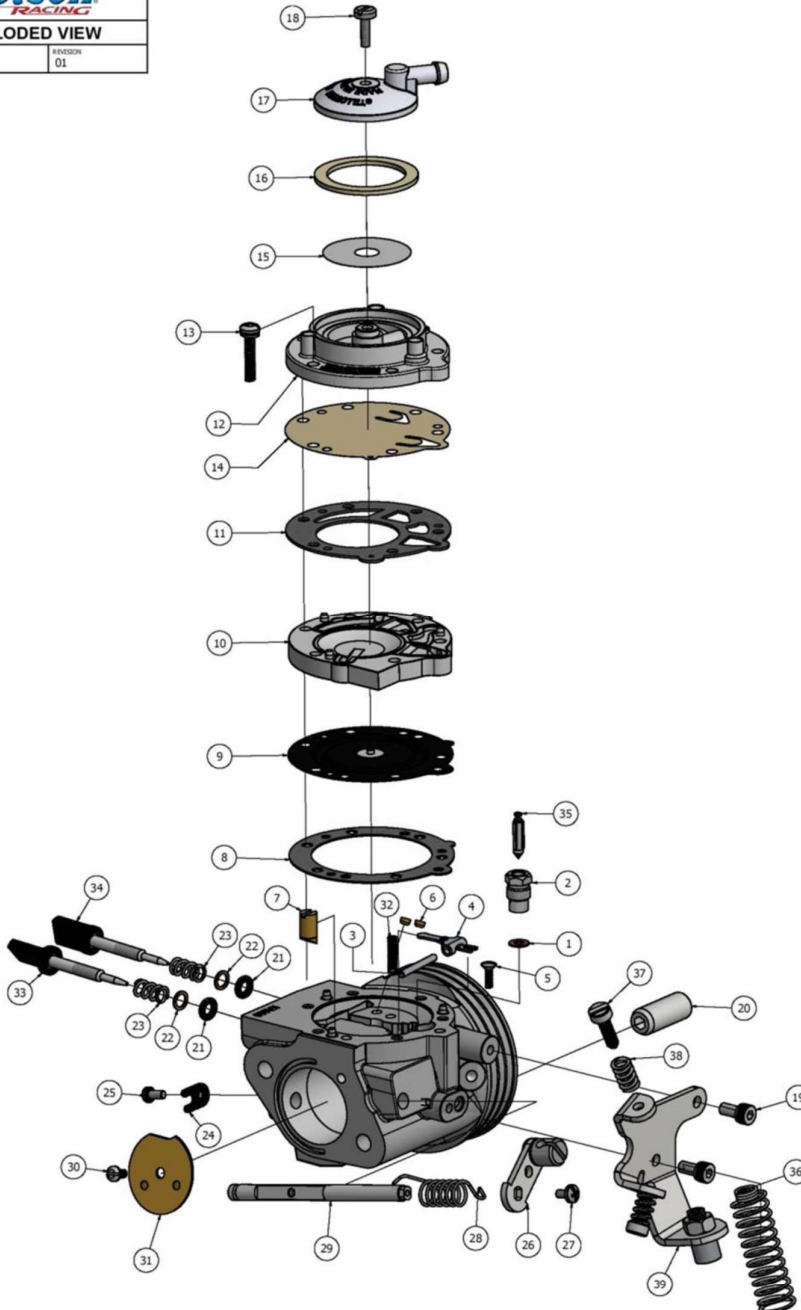

ITEM	QTY	PART NUMBER	DESCRIPTION	ITEM	QTY	PART NUMBER	DESCRIPTION	ITEM	QTY	PART NUMBER	DESCRIPTION
1	1	16-B199	+* INLET SEAT GASKET	17	1	91-A251	FUEL STRAINER COVER	33	1	43-1029	8-32 UNC ADJUSTMET SCREW ASSEMBLY
2	1	36-A42	+ INLET SEAT	18	1	15-B313	5-40 UNC SCREW	34	1	43-1030	8-32 UNC ADJUSTMET SCREW ASSEMBLY
3	1	32-79	FULCRUM LEVER PIN	19	2	15-C67	M4 X 0.7 SOCKET CAP SCREW	35	1	34-216	+ INLET NEEDLE
4	1	155-A27	+ INLET CONTROL LEVER	20	2	81-377	CARBURETTOR MOUNTING NUT	36	1	24-C334	CABLE RETURN SPRING
5	1	15-B329	FULCRUM PIN SCREW	21	2	44-361	ADJUSTMENT SCREW O-RING	37	2	15-C9	LIMITER SCREW
6	2	80-160	BRASS PLUG	22	2	78A-256	ADJUSTMENT SCREW WASHER	38	2	24-B131	SPEED CREW SPRING
7	1	363-318	IDLE NOZZLE	23	2	24-B449	ADJUSTMENT SCREW SPRING	39	1	136-A55	CABLE BRACKET
8	1	16-B217	+* DIAPHRAGM GASKET	24	1	29-224	THROTTLE SHAFT CLIP			*	REPAIR KIT CONTENTS
9	1	237-600	+* DIAPHRAGM ASSEMBLY	25	1	15-C19	4-40 UNC SCREW			+	DIAPHRAGM & GASKET KIT CONTENTS
10	1	91-A275	FUEL PUMP BODY	26	1	12-1220	THROTTLE LEVER ASSEMBLY				
11	1	16-B392	+* FUEL PUMP GASKET	27	1	15-C52	4-40 UNC SCREW				
12	1	141-89	FUEL PUMP BODY	28	1	24-B381	THROTTLE RETURN SPRING			RK-6HW	REPAIR KIT
13	6	15-C51	6 - 32 UNC SCREW WITH LOCK WASHER	29	1	13-B216	THROTTLE SHAFT			DG-3HW	DIAPHRAGM & GASKET KIT
14	1	237-162	+* FUEL PUMP DIAPHRAGM	30	1	15-C20	4-40 UNC SCREW			233-721P	INLET NEEDLE & SEAT SET
15	1	95 - 170	FUEL STRAINER SCREEN	31	1	14-A118	THROTTLE SHUTTER				
16	1	16-B205	+* FUEL STRAINER COVER GASKET	32	1	24-B299	INLET TENSION SPRING 37g				

SPARK PLUG CLEANING AND REPLACEMENT



Sparkplug wrench
Metal Brush



Risk of burning: Perform this task **ONLY** when engine is cool.

Oils produce carbon deposits or residues that make necessary the spark plug to be checked and cleaned, at least every 5 hours.

Remove the spark plug and clean it by using a brass metal brush.

Use a specific spark plug gap gauge to set up correct gap. Correct gap: **0.8 mm**.

Every 30 hours it is highly recommended to change the spark plug.

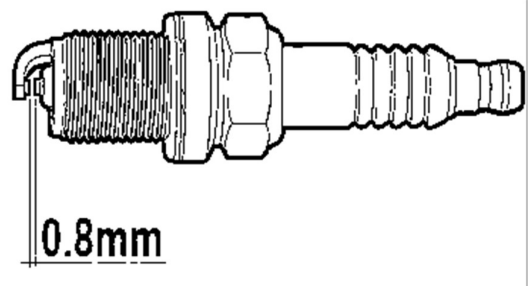

EXHAUST CLEANING



Metal Brush
Heater

Oils produce carbon deposits or residues that make necessary the exhaust to be checked and cleaned, at least every 10 hours.

Disassemble the exhaust from the engine by removing the two springs and check the exhaust carefully.

Heat the exhaust with a heater and remove all carbon deposits with a metal brush.

CYLINDER HEAD CLEANING



10 mm tube wrench
Torque wrench
Spark plug wrench

Oils produce carbon deposits and/or residues that make necessary cylinder head to be checked and cleaned, at least every race.



Be aware, cylinder head combustion chamber volume may vary during the race. Carbon deposits may cause variations in cylinder head volume.

Remove spark plug. Remove the four head nuts and relative washers.
Remove cylinder head by pulling it up carefully.



Use rubber gloves.

After cleaning the combustion chamber with fuel, reassemble cylinder head.

This specific washer, assembled wrongly, will change the combustion chamber volume. Insert carefully the head on to the studs, insert washers and nuts in the studs and tight them manually. Now, by using a dynamometric wrench tighten them alternatively at **16 Nm**.

CYLINDER CHECK AND MAINTENANCE



10mm tube wrench
Torque wrench



To avoid engine damage, a Vortex qualified mechanic must perform inspection and honing.



Remove exhaust.
Remove spark plug. Remove the four head nuts and relative washers.

Remove cylinder head by pulling it up carefully.
Remove the cylinder from the crankcase slowly. Once cylinder is separate from crankcase, hold the connecting rod with the other hand and pull the cylinder out totally by pulling it up carefully.
Every time cylinder is removed we recommend changing cylinder gasket.



Cylinder must be honed when the cylinder/piston clearance is more than **0.145mm** or when ovalization is more than **0.02 mm**.

Change piston (see *PISTON CHECK AND MAINTENANCE*).
New piston cylinder/piston clearance must be **0.12mm**.

REASSEMBLING

Insert a new gasket on to the studs carefully and place it in the crankcase surface flat.
Insert now the cylinder in the studs very carefully. With the other hand close piston ring and inset the piston into the cylinder. If piston ring is not closed totally, risk of cylinder and piston ring is very high Push the cylinder down firmly.

Insert cooper washer. Please check cooper washer is located in the right position.
This specific washer, assembled wrongly, will change the combustion chamber volume.
Install, carefully, the head onto the studs and check all O-rings are fitted in the right place. If any is damaged, change it.
Install washers and nuts onto the studs and tight them manually. Now, by using a dynamometric wrench tighten them alternatively at **16 Nm**.



Every time cylinder is honed or piston changed, the engine break-in procedure must be performed.

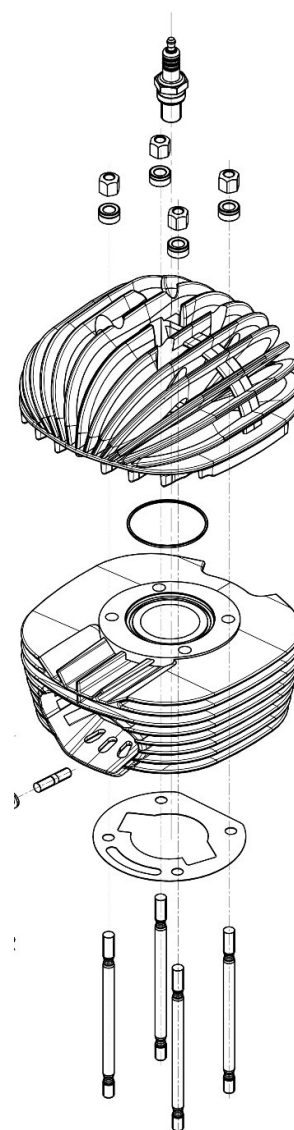

PISTON CHECK AND MAINTENANCE



10 mm tube wrench
Torque wrench



To avoid engine damage, a Vortex qualified mechanic must perform inspection and honing.



Remove exhaust.
Remove spark plug. Remove the six head nuts and relative washers.

Remove cylinder head by pulling it up carefully.

Once cylinder is separate from crankcase, hold the connecting rod with the other hand and pull the cylinder out totally by pulling it up carefully.

Every time cylinder is removed we recommend changing cylinder gasket.

Remove the circlips from the piston pin. Push the pin out of the piston.

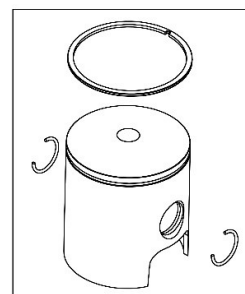
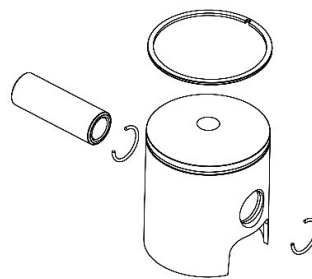

Before assembling a new piston check dimensional sizes. Correct cylinder/piston clearance is **0.12mm**. ASSEMBLING

Oil and insert the roller cage in the connecting rod.

Install the new piston in the connecting rod by placing the arrow stamped in the head of the piston facing the exhaust port.

Insert now the piston pin and secure it with the circlips.



Attention, wrong circlips assembling may cause serious damage.

Insert the piston ring in the piston carefully. Check both ends of the piston ring when totally closed have a gap of **0.30 mm, 0.40 MAX**.

Now you are ready to assemble cylinder and cylinder head.



Engine needs a brake-in in session when a new piston has been placed.

CLEANING AND/OR REPLACING CLUTCH

1. Disassemble the clutch cover.
2. Take away the Bendix cover
3. Stop the clutch drum by using the special tool designed by Vortex for this specific task.
4. Unscrew **anticlockwise** the nut on the clutch drum (92). Remove the washer (91), clutch drum (87) and roller bearing (90).
5. Unscrew the three 6x14mm Allen screws (79) on the clutch.
6. Unscrew **clockwise** the central nut (84) by using a 24mm fixed wrench to remove it. Stop the starter gear with the specific tool manufactured by Vortex.
7. Take away the clutch (82) by using the appropriate extractor.
8. Before assembling the new clutch, we recommend to clean the clutch area and the pinion bell with a solvent.

ASSEMBLING

9. Install the new clutch (82) on the crankshaft by pushing lightly with your fingers and secure it with the three 6x14mm Allen screws (79). Use thread locker to secure them.
10. Put together again the elastic washer (83) and the central nut (84) and tighten. Use thread locker to secure the central nut.
11. After screwing the central nut place the washer (85).
12. Grease the needle bearing (90) totally and insert it on the crankshaft.
13. Place the clutch bell (87), the spacer (91) and screw the nut (92). Use thread locker to secure it.
14. Re-place Bendix cover.
15. Re-place the clutch cover.

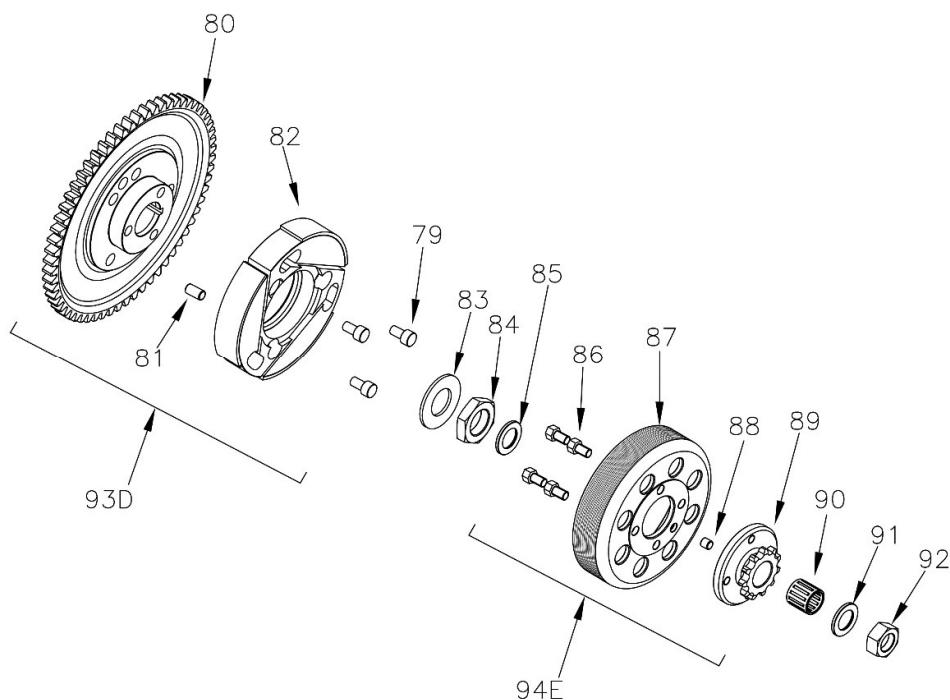

REPLACING STARTER GEAR

1. Disassemble the clutch cover.
2. Take away the Bendix cover
3. Stop the clutch drum by using the special tool designed by Vortex for this specific task.
4. Unscrew **anticlockwise** the nut on the clutch drum (92). Remove the washer (91), clutch drum (87) and roller bearing (90).
5. Unscrew **clockwise** the central nut (84) by using a 24mm fixed wrench to remove it. Stop the starter gear with the specific tool manufactured by Vortex.
6. Take away the clutch (82) together with the starter gear (80) by using the appropriate extractor.
7. Unscrew the three 6x14mm Allen screws (79) on the clutch.
8. Before re-assembling, we recommend to clean the area with a solvent.

ASSEMBLING

9. Screw the new starter gear (80) to the clutch (82) by using three 6x14mm Allen screws (79). Use thread locker to secure them.
10. Insert the starter gear and clutch on the crankshaft by pushing lightly with your fingers.
11. Put together again the elastic washer (83) and the central nut (84) and tighten. Use thread locker to secure the central nut.
12. After screwing the central nut place the washer (85).
13. Grease the needle bearing (90) totally and insert it on the crankshaft.
14. Place the clutch bell (87), the spacer (91) and screw the nut (92). Use thread locker to secure it.
15. Re-place Bendix cover.
16. Re-place the clutch cover.