



**2019 ROK the RIO
EVENT SUPPLEMENTARY REGULATIONS**

October 30 – November 2nd

Version 1 October 20, 2019

Organizer

ROK CUP Promotions

10003 Satellite Blvd Orlando, FL 32837

1 (407) 438-7734

Series Director: Garrett Potter

Sporting Director: Chuck Yoder

Technical Director: Dave Davies

Event Dates and Location

The event takes place at Rio All-Suite Hotel Casino, 3700 W Flamingo Rd., Las Vegas, NV 89103
(866) 746-7671 Website www.riolv.com

Official practice will take place Wednesday, October 30st, 2019. Qualifying/Heats/Mains events take place from Thursday, October 31st - Saturday, November 2nd, 2019.

Racetrack

The track has a length of 0.73 miles and has 12 corners. All sessions will run counter clockwise.

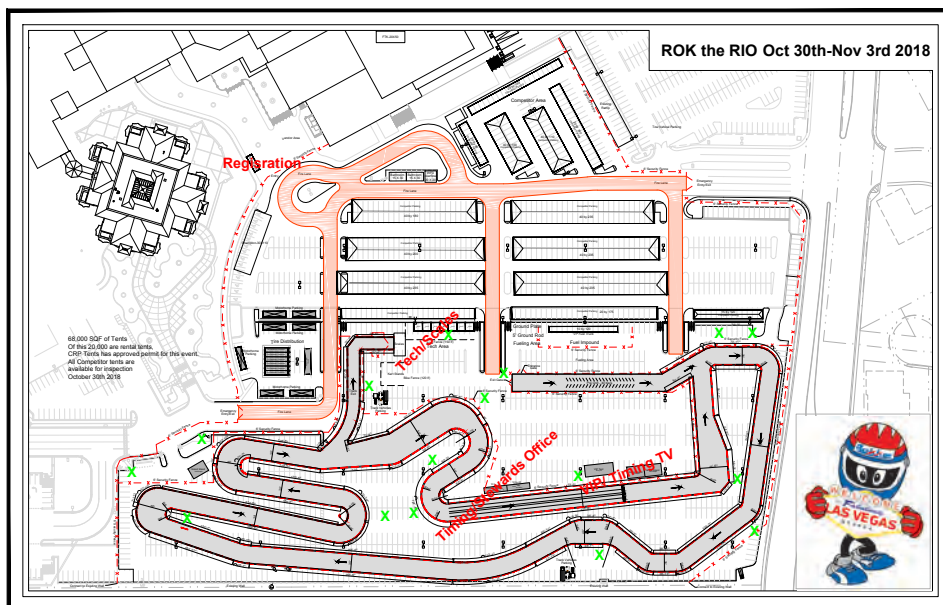

Classes and Kart Numbers

Class:	Numbers
ROK Micro	1-99
ROK Mini	100-199
ROK VLR Junior	900-999
ROK VLR Senior	700-799
ROK VLR Masters	800-899
ROK Junior	200-299
ROK Senior	300-399
ROK Masters	600-699
ROK Shifter	400-499
ROK Shifter Masters	500-599

Senior Officials

Chief Steward:	Robbie Poupart	Timing & Scoring:	Jonathan Perdomo
Ass. Steward:	Marc Miscione		
	Philippa Tuckey	Assistant T & S:	Pam Haines
		Chief Grid Marshal:	Cierra Ebert
Penalty Secretary:	Philippa Tuckey		Guy Keesee
Video Steward:	Joe Dobson	Chief Registrar:	Ursula Ustariz
Race Director:	Chuck Yoder	Ass. Registrar:	Eileen de Bustos
Asst. Race Director:	Rick Hall		Pam Haines
	Bobby Radivoy	Chief Technical Insp.:	Dave Davies
	Darren McDonough	Assistant Tech. Insp.:	Robert Yardley
	Mark Baudin		Tom Martinet
	Jeff Richmond		
	Justin Dittrich	Scale:	Eileen de Bustos
Starter:	Dennis Long		Steve Haines
			Dominic Favalora

Driver's Briefing

Driver's briefings are mandatory and all drivers must attend. Either they appear on the schedule or are called during the event on the Public Announcement system. Presence may be controlled physically or electronically. For this reason, drivers must have their credentials with them at the briefing.

Paddock

Competitors must receive authorization from the event staff before setting up their pit space. The paddock is restricted for race support vehicles only; aisle may not be blocked at any time; to allow emergency vehicle to access. Clark County Fire has a very strict policy (stated requirements below), the fire department will send an inspector on Tuesday, October 30th to make sure every pit is compliant; they have the authority to shut down the event for one pit area not compiling, so please help your neighbors.

“NO race fuel is allowed in the paddock area; all race fuel will need to be stored in the fuel compound (see map), fuel tanks attached to the kart are ok. You will be allowed 5 gallons of generator fuel only per pit. This fuel can must be stored outside the trailer and tent area. All pits areas are required to comply with the following: Pit area will have a minimum of one 5-lb type ABC rated fire extinguisher for every 400 square feet of pit area; fire extinguishers must be visible and accessible at all times; competitors with trailers over 20-ft long shall have a minimum of one 20-lb type ABC fire extinguisher for the trailer in addition to one 5-lb unit for each 400 square feet of pit area. Non-compliance could result in fines or driver penalties.”

All RV's will be required to park in the RV lot; these lots are dry camping only.
All spectators will be required to park in the parking garage or with hotel valet.
Any motorized vehicle (car, truck, golf cart, etc) must be operated by someone who is 16 years old or older. Any violation of this will result in vehicle confiscation for the event week and possible fines.

Registration

Pre Registration for the event closes Monday, October 21st, 2019 and can be found here: www.rokcupusa.com Onsite registration will open Monday, October 28th at 1:00PM and closes Wednesday, October 30th at 5:00pm, local time.

Event Fuel and Oil

Fuel

The mandatory fuel is Sunoco supremum included in the registration. Distribution of event fuel will take place at the fuel compound, times can be found on the event schedule. Anyone needing to purchase practice fuel can buy “fuel vouchers” from registration. All fuel must be mixed and stored in the fuel compound area, please make sure you mark your cans clearly.

Oil

The mandatory oil is Motul Kart Grand Prix 2T, which is supplied with the registration.

Mandatory Stickers

Event stickers and location are required, this information can be found in your packet or at registration. These are a tech item penalties may be enforced if not compliant

Event Tires

The event tires are the following for each class.

Slick tires

Classes	Tires brand	Sizes
ROK Micro/Mini	Bridgestone YLR	6 Front 4.5/10.0-5
100 CC	Bridgestone YLR	3 Front 4.5/10.0-5 3 Rear 7.1/11.0-5
ROK Junior, Senior, Masters, Shifter, Shifter Masters	Bridgestone YLR	4 Front 4.5/10.0-5 4 Rear 7.1/11.0-5

Rain tires

Classes	Tires brand	Sizes
ROK Micro/Mini	Bridgestone YLP	8 Front 4.5/10.0-5
ROK Junior, Senior, Masters, Shifter, Shifter Masters, 100CC	Bridgestone YLP	4 Front 4.5/10.0-5 4 Rear 6.0/11.0-5

All Rain Tires MUST be barcoded.

Parc Fermé

There is no Parc Fermé for this event. Exception for fuel

Sealed Grid

Sealed grid will be enforced for qualifying and racing sessions.

Quiet Grid

You MUST run your engines in your designated pit areas ONLY!!! All other areas are restricted from running engines including but not limited to Pre-Grid, Tech, scales, aisle ways. Anyone not following this rule is subject to a fine of \$200 per offence.

Hot Pit

There is no Hot Pit during this event.

Length of Races

See the official schedule of the event.

Grouping If Necessary

After the end of the Registration period, some classes may be grouped together depending on the number of entries.

Cameras

Up to two cameras may be installed on the competitor's kart, cameras can be forward or rearward facing. No camera will be mounted higher than the top of the driver's fairing, cameras must be tethered. Cameras are for personal use only and cannot be submitted to event officials to support an investigation, protest or appeal. Only the event cameras will be used by officials regarding official's decisions. Officials may install cameras on a competitor's kart at any time as they see fit.

Sporting Regulation

The 2017 ROK CUP USA Sporting Regulations will be used with the modifications contained in these Event Supplementary regulations. Any regulation not covered will revert to the international CIK regulation.

Technical Regulation

Eligible Engines for 100CC Classes

ROK VLR 100-ROK Technical Regulations
Iame KA100-WKA Technical Regulations

Engine Claim Rule

Any engines taking part in a ROK Cup Promoted event, can be purchased by any competitor taking part in the event. ROK CUP or its affiliated promoters have the first right of refusal on any claim. The competitor must be registered for the event and in the same class, and only at the end of the event. ROK Cup Promotions, or its affiliated promoters have the right to claim any engine at anytime. The fee is retail price of the engine plus \$500 (Five Hundred) claim fee. The claimed party will receive the claim fee and a new engine from ROK CUP or the affiliated promotor.

Refusal to sell will result in disqualification from the event, loss of all championship points, and the competitor will NOT be allowed to compete in any ROK CUP event for 12 (twelve) consecutive months.

All Claim fees MUST be paid in full in the form of US dollars, cash ONLY, form and cash must be returned to ROK CUP Promotions admin or the affiliated promoter.

Tech officials are required to return the engine back to its factory settings (carburetor settings, ignition settings), before delivering to the new owner. Claim will be kept anonymous

Reeds

New style reeds will be required for GP/Shifter (6/1/17 update)

GP:

[Part # W392/V5](#)

Shifter:

[Option #1. Part # W10221/1](#)

[Part # W10221/M](#)

[Option #2](#)

[Part # W10221/1](#)

[Part # W10221/1](#)

See attached Document

Power Valve

New style power valve must be used, old adjustable red top in not allowed

Micro ROK

Main Jet is open

Gear 11/82 or 10/75

GP Radiator

Both New GP Radiator Part #0093.TAB and old style Part #0093.TB are allowed, see attached document.

New VLR Piston

Part #W700011100040. Sizes A,B,C,D, E,F are allowed, See attached document

Engine warming

Water cooled engines will be allowed to use HotHead water heating system.

Battery

The use of lithium ion batteries is approved but must meet factory sizing specifications.

Weights

Class	Age	Weight	Engine	Rear Width	Other
Micro Rok	7/9	230 lbs.	Mini Rok	50 in	Fixed gear, Exhaust restrictor.
Mini Rok	8/12	245 lbs.	Mini Rok	50 in	
Junior Rok	12/15	320 lbs.	Rok GP	55 1/8 in	Exhaust restrictor.
Senior Rok	15	355 lbs.	Rok GP	55 1/8 in	
Master Rok	32+	390 lbs.	Rok GP	55 1/8 in	+ 190 lbs body weight
Shifter Rok Senior	15	395 lbs.	Rok Shifter	55 1/8 in	
Shifter Rok Master	32+	410 lbs.	Rok Shifter	55 1/8 in	+ 190 lbs body weight
Junior 100cc	12/15	310 lbs.	ROK VLR / IAME KA100	55 1/8 in	
Senior 100cc	15	350 lbs.	ROK VLR / IAME KA100	55 1/8 in	
Master 100cc	32+	380 lbs.	ROK VLR / IAME KA100	55 1/8 in	+ 190 lbs body weight

Technical Inspection

All competitors will be required to complete a technical inspection form provided in the registration packet. Times for these forms to be completed and turned in is posted on the daily schedule. All competitors will receive one engine and one chassis seal in the registration packet. These must be installed prior to qualifying. Anyone needing to check in a second engine must present both engines to tech for inspection, Tech officials will at that time issue an additional seal.

Chassis Eligibility

CIK homologated 2009 or newer, ROK CUP USA, WKA or other national organisations approved.

SteeringHub

Option 1-Standard hub (no angle), Option 2-One angled hub, Option 3-One angled hub with one angled spacer. Angles may not be achieved with washers.

Official Posting Board

The Official Posting Board is located next to the scale exit ramp.

Protest and Appeal Fees

If a competitor wants to officially Protest a decision from the officials, he or she must follow the regulations included in the 2017 ROK CUP USA regulations. The Protest fee for this event is two hundred dollars (\$200.00) payable in cash when the Protest is filed.

In the case that a competitor wants to Appeal a decision made on a Protest, he or she must follow the regulations included in the 2017 ROK CUP USA regulations. The Appeal fee for this event is one thousand dollars (\$1000.00) payable cash when the Appeal is filed. **Appeal forms will only be available for final events, from the Steward's office.**

ROK SHIFTER

OPTION #1

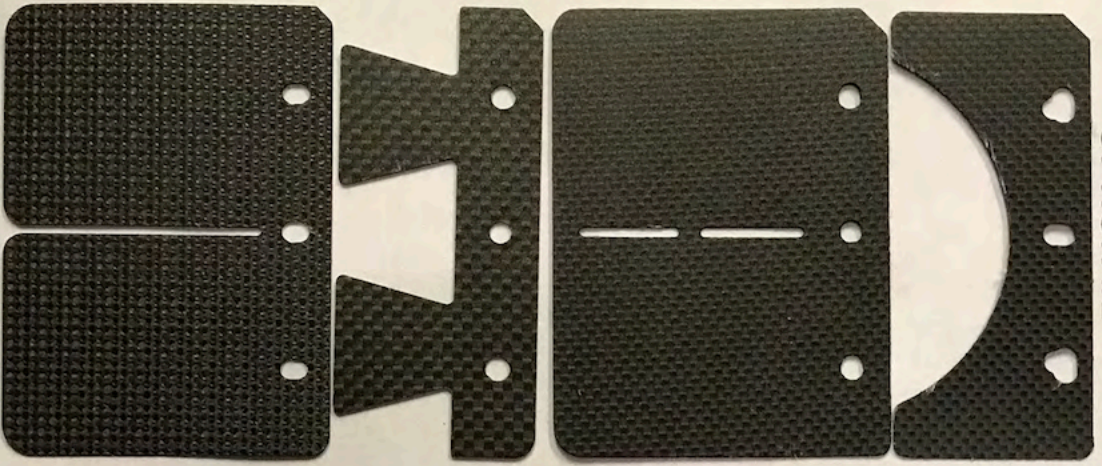

TOP

BOTTOM

OPTION #2

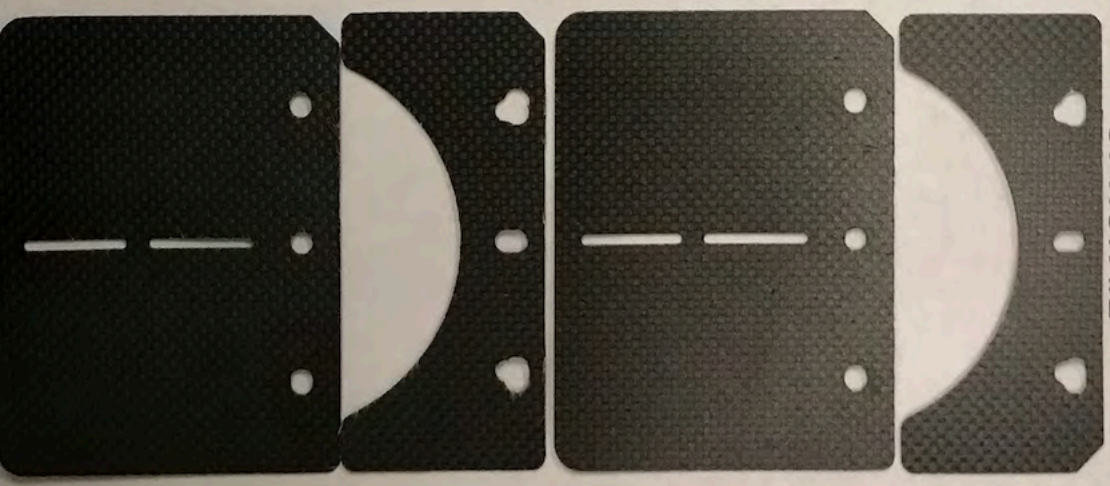

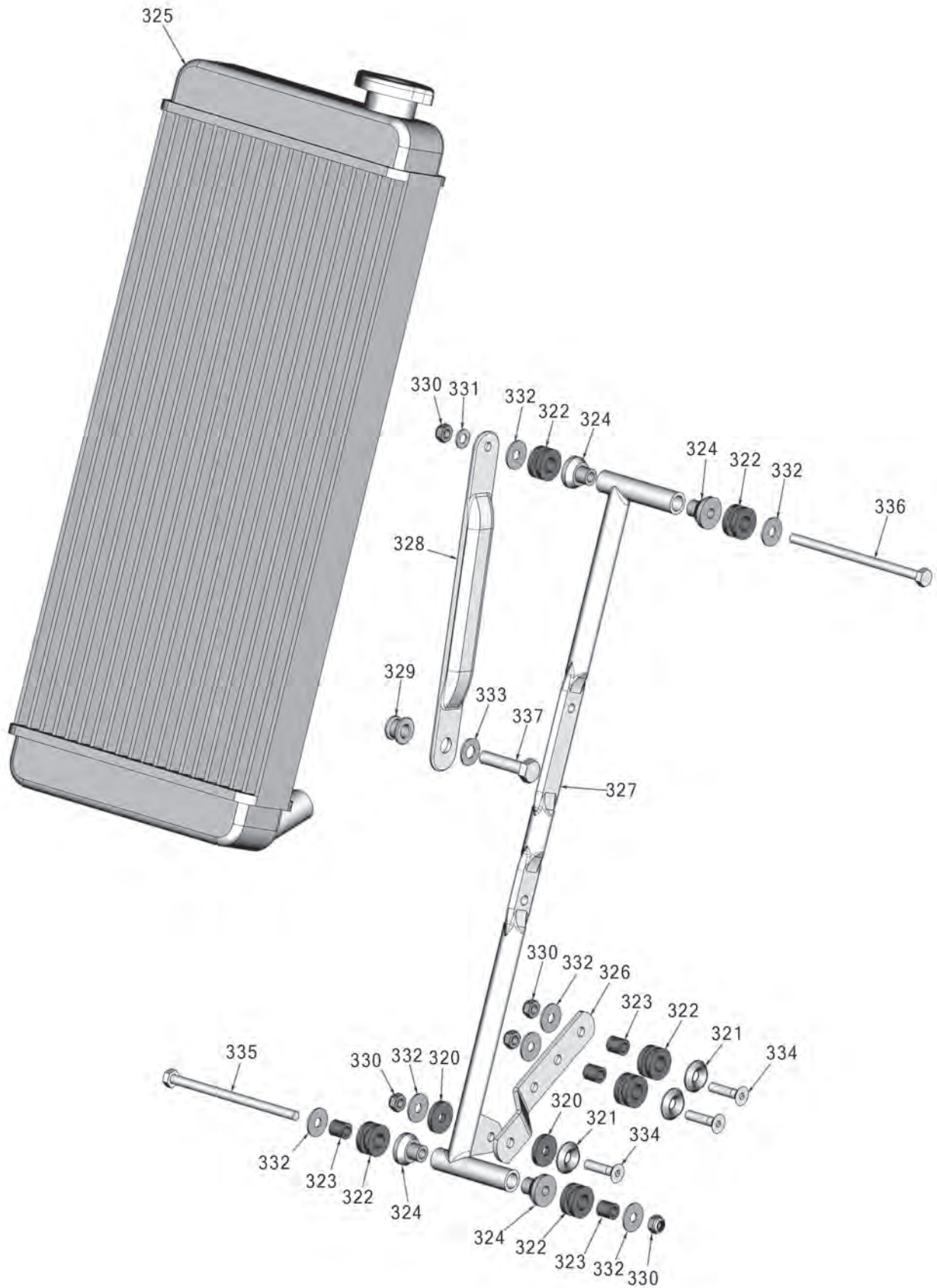



FORM OF <u>VO</u> VARIANT OPTION	Rif. HOMOLOGATION FORM for VLR ENGINE cl. 100 cc.
---	--



VORTEX FACTORY OTK KART GROUP s.r.l. Via E. Fermi, 5 I - 27040 PAVIA	HOMOLOGATION FORM for VLR ENGINE cl. 100 cc.
Manufacturer	OTK Kart Group
Make	VORTEX FACTORY
Model	ROK VLR
Validity of the VO	IMMEDIATE
Number of pages	2
DESCRIPTION OF THE <u>VO</u>, VARIANT OPTION	
<ol style="list-style-type: none"> 1. New production of the part, PISTON 2. Technical features and visual differences: The piston has a new graphite coating and inside the VORTEX logo is marked in relief. 3. After the tests carried out the same reliability and performance of the part previously used was verified. 	

TECHNICAL INFORMATION		
	Measurement	Tolerances
Volume of combustion chamber	8.60 cc	Min
SQUISH	1 mm	Min

PART	MATERIAL	WEIGHT	TOLERANCES
PISTON	ALLOY	97g (+ Piston Ring)	+/- 5g



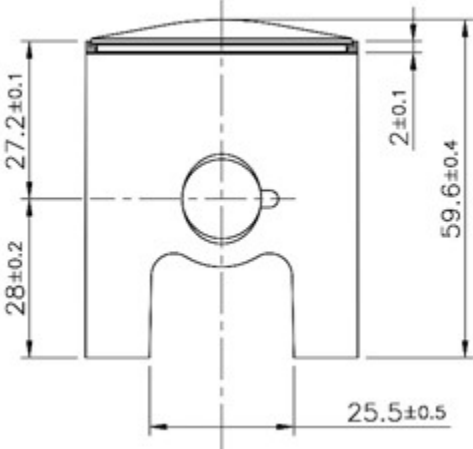

PISTON Weight 97g	PISTON PICTURE
	

VORTEX LOGO POSITION	VORTEX LOGO POSITION
